

---

# IOT BASED SMART WEARABLE DEVICE FOR WOMEN SAFETY

**Sunita Malaj**

*Assistant Professor, EC Dept, Hirasugar Institute of Technology, Nidasoshi*

*Corresponding Author Orchid ID: <https://orcid.org/0009-0001-4608-5623>*

## ABSTRACT

Women safety has been a big concern and it has been the most important duty of every person. There is no chance of the welfare of the world unless the condition of the women is improved. Since the ancient time, women are given most respected place in the society but every day and every minute some women of all walks of life (women, girls and babies) are getting harassed, molested, assaulted and violated at various places all over the world. It is estimated that 35% of the women have experienced physical and/or sexual violence at some point in their lives. This work deals with the development of smart wearable device for women safety using IOT. This consists of a device which can be used as a wearable in day to day life. When the girl is in danger the device is activated which will send the GPS coordinates for tracking to the android application developed which can be tracked regularly. It also consists of a camera module to capture the photos and send it to the app if the girl is in danger. The system also consists of an SOS alert to grab the attention of nearby people. The SMS Notification will also be sent to the family members and police station when the girl is in danger. This proposed wearable device can serve a solution to the problems faced by the learning if violated.

## I-INTRODUCTION

In this twentieth-century where everyone is allowed to do whatever they want and to roam wherever they wish to go. There is a section or say half the section of the society who are still constrained to live their lives to the fullest. Yes, we are talking about females. Women are still suffering from various inequalities. According to the National Crime Records Bureau, in 2015, there were over 300,000 reported incidents, a 44% increase from 2011 crimes against women. They are the foundation of any economy essentially forming the eventual fate of the nation. She who earlier stayed at home to attend her domestic duties is now maintaining work and home simultaneously, participating in the process of economic development on an equal footing with men. So, it is the time to think about their safety and it is possible through IOT (Internet of Things). The main answer for the issue can be taken so that the women ought to be allocated with a well-being device that is convenient and guarantees her security. Our task centers around giving a Smart contraption dependent on IOT arrangements that not just serve to female get away from the basic circumstances but also additionally guarantees to give equality to the women. IOT is the colossal number of interconnected gadgets over the web fit for overseeing computerized undertakings adroitly with no direct human inclusion. As time is passing, an ever-increasing number of gadgets are being interconnected and IOT is turning into an indispensable piece of our lives which permits us to play out the day by day undertakings quicker and proficiently, and in manners, we couldn't previously. In a perfect world, IOT will upgrade the future schedules with canny and solid frameworks that will make our way of life calm and furthermore adjust to the ever-developing needs. It will empower us to have totally robotized frameworks that will have its applications in making our security courses of action astute, by evacuating the client obstruction with any security gadget.

## II-LITERATURE SURVEY

Before we start with the work a brief literature survey about the work was carried out. This involves studying the current approaches, the problems, the solutions provided by the different

research scholars to arrive at the problem definition and propose and implement the solutions for the same. The number of research papers from different national and international journals was studied to arrive at the problem definition. Some of the important approaches and research work carried in this field is outlined in this section.

Seelam and Prasanti (2018) [1] says that in today’s world women are less secure and have many issues regarding their security purpose. This paper describes about safe and secured electronic system for women which comprises of an Arduino controller and sensors such as temperature LM35, flex sensor, MEMS accelerometer, pulse rate sensor, sound sensor. A buzzer, LCD, GSM and GPS are used in this work. When the woman is in threat, the device senses the body parameters like heartbeat rate, change in temperature, the movement of victim by flex sensor, MEMS accelerometer and the voice of the victim is sensed by sound sensor. When the sensor crosses the threshold limit the device gets activated and traces the location of the victim using the GPS module. By using the GSM module, the victim’s location is sent to the registered contact number.

Prof. Kiran et al (2017)[2] says that, in today’s world, security is the major issue for an individual. In this work the system consists of a monitoring device, which gets activated when the device is tapped upon then a text message along with voice alert message is received by the respective emergency contacts. Further the person who receives the notifications can find and track the location without the interaction of the victim’s application at each and every function.

### III-METHODOLOGY

#### Block Diagram Description

**Figure 1: Smart wearable device for women safety**

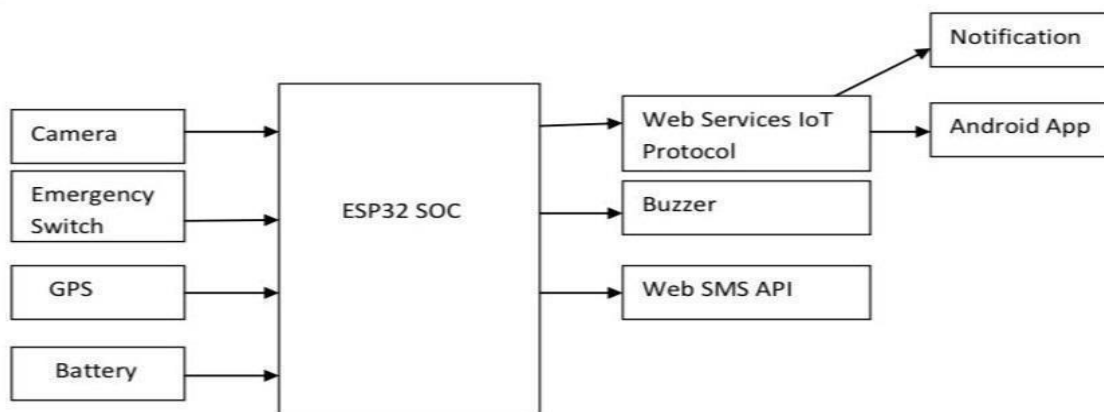

As shown in the diagram above the system consists of development of IOT based smart wearable device for Women safety. The system consists of an EPS32 SOC which is interfaced to the different sensors and the GPS modem. The sensors such as push button will activate the device when the girl is in danger and start sending the GPS coordinates to the android application for live tracking as well as send the notification to the family members. The ESP32 SOC will take the data from the sensors as well as communicate with the cloud backend hosted remotely using web services API and IOT protocols. The GPS modem will fetch the live location and send it to the tracking application. The camera module will capture the live images and send it to the android application intermittently.

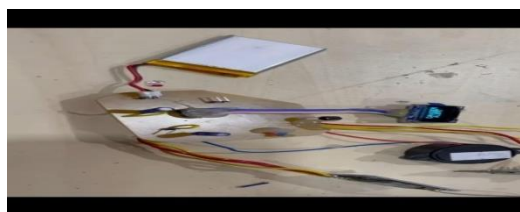

**Figure 2. Hardware Design**

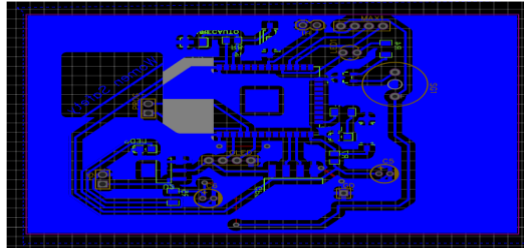

**Figure 3. PCB Board**

The following steps of methodology have been identified for the conduct of the work. The proposed system deals with the development of women safety wearable device and tracking on mobile application. The methodology to carry out the Work is as given below:

- Literature Review and Problem Definition
- Material selection
- Interfacing Camera module to ESP32
- Development of SOS alert system
- Development of GPS Tracking system .
- PCB hardware Design
- Fabrication
- Assembly
- Programming
- Android Application Development.

#### **IV.COMONENT DESCRIPTION**

##### **A.ESP 32 Wi-Fi SOC**

**Figure 4.ESP 32 Wi-Fi 33 SoC**



WIFI module: ESP-WROOM-32

Processor: ESP32-D0WDQ6

Built-in Flash: 32Mbit

Antenna: Onboard PCB antenna

Peripheral Interface:

UART/GPIO/ADC/DAC/SDIO/PWM/I2C/I2S

Wi-Fi protocol: IEEE 802.11 b/g/n

Bluetooth: Bluetooth 4.2

Frequency range: 2.4G ~ 2.5G (2400M ~ 2483.5M)

WIFI mode: Station / SoftAP / SoftAP+Station

##### **B.OV2460 CAMERA MODULE**

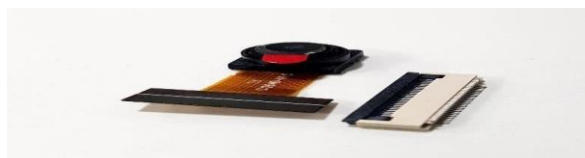

**Figure 5: Camera Module**

OV2640 is a 1/4-inch CMOS UXGA (1632\*1232) image sensor Standard SCCB interface .Small in size. Video or snapshot operation.

### C.PUSH BUTTON



**Figure 6: push button**

The push button is used to activate the emergency mode. The 2-leg pushbutton is use in this work.

### D. UBLOX NEO6M GPS MODEM



**Figure7: Ublox Neo6m GPS modem**

### E.OLED DISPLAY



**Figure 8: OLED display**

OLED (Organic Light Emitting Diodes) is a flat light emitting technology, made by placing a series of organic thin films between two conductors. When electrical current is applied, a bright light is emitted. OLEDs are emissive displays that do not require a backlight and so are thinner and more efficient than LCD displays (which do require a white backlight).

### F.BUZZER

**Figure 9: Buzzer**



The buzzer consists of an outside case with two pins to attach it to power and ground. Inside is a piezo element, which consists of a central ceramic disc surrounded by a metal (often bronze) vibration disc. When current is applied to the buzzer it causes the ceramic disc to contract or expand. Changing this then causes the surrounding disc to vibrate. That's the sound that you hear. By changing the frequency of the buzzer, the speed of the vibrations changes, which changes the pitch of the resulting sound.

### G.LIPO BATTERY



**Figure 10: Lipo Battery**

### V-RESULTS & DISCUSSION

The software used to program the microcontroller is the Arduino IDE. Arduino is an open-source computer hardware and software company, project and user community that designs and manufactures kits for building digital devices and interactive objects that can sense and control the physical world. Arduino boards may be purchased preassembled, or as do-it-yourself kits; at the same time, the hardware design information is available for those who would like to assemble an Arduino from scratch. The work is based on a family of microcontroller board designs manufactured primarily by Smart Projects in Italy, and also by several other vendors, using various 8-bit Atmel AVR microcontrollers or 32-bit Atmel ARM processors. These systems provide sets of digital and analog I/O pins that can be interfaced to various extension boards and other circuits.

The boards feature serial communications interfaces, including USB on some models, for loading programs from personal computers. For programming the microcontrollers, the Arduino platform provides an integrated development environment (IDE) based on the Processing project, which includes support for C and C++ programming languages.

**Flowchart of the system**

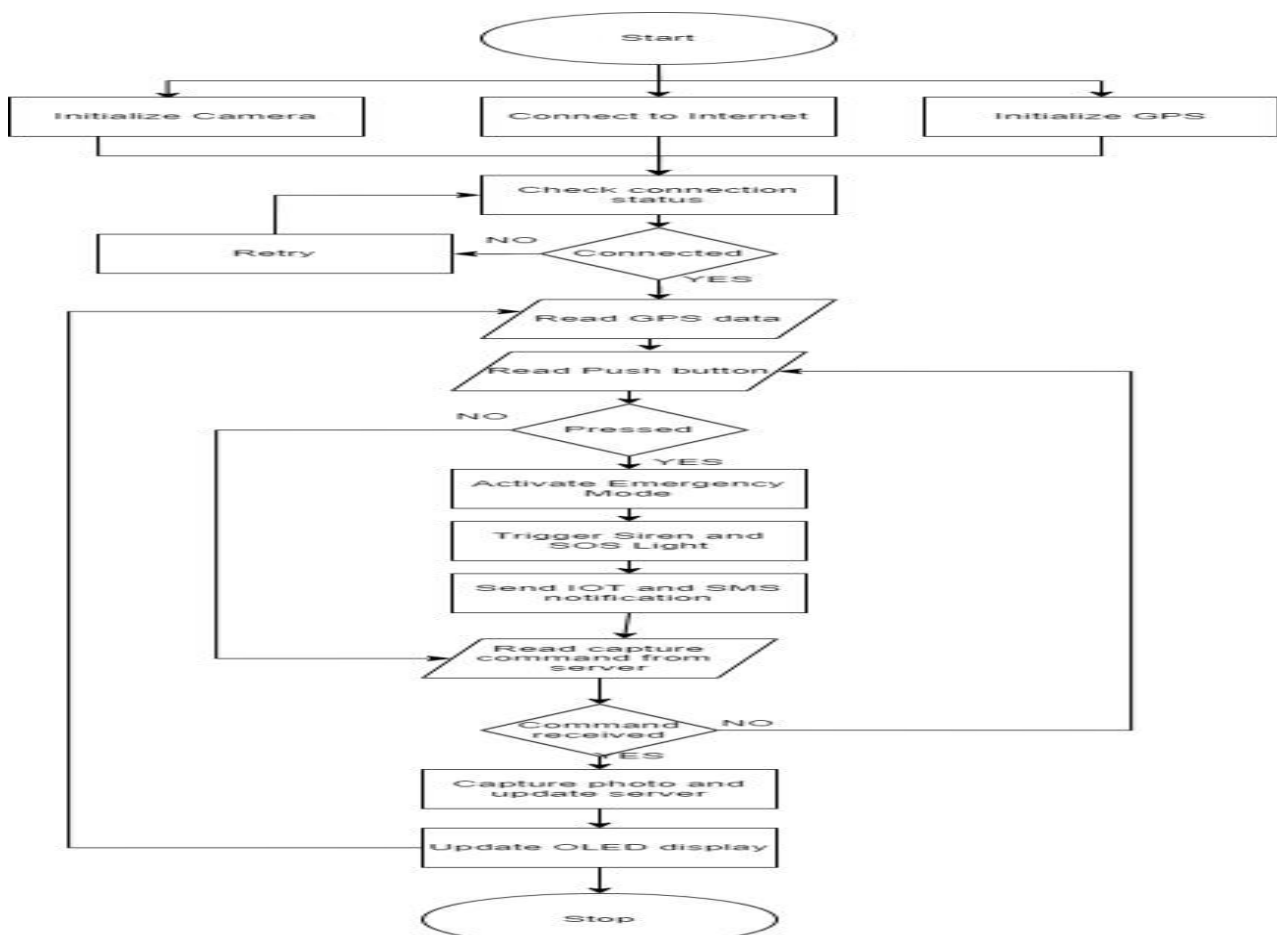

**Figure 11 : Flow Chart**

### V-CONCLUSION

By doing this work it is concluded that, women can travel through any remote area at anytime. We can also provide the safety for the women. Even though she is in danger we can able to detect easily..

The work deals with the development of the women safety wearable device using IOT. We can conclude that the project can help keep the women safe by providing them with a wearable solution to tackle the ever increasing problem of women safety. From the implemented project we can conclude that the device will help the girls in danger to receive immediate help by providing them with a device to activate when in danger. Once activated the device will generate a SOS and also send the GPS

coordinates which can be tracked using android application developed over IOT. The camera will capture images which will serve additional safety. Thus the device will serve as a safety device for women and avoid crimes against women.

## REFERENCES

- [1]. Kalpana seelam, K. Prasanti, "A NOVEL APPROACH TO PROVIDE PROTECTION FOR WOMEN BY USING SMART SECURITY DEVICE", IEEE International Conference on Inventive Systems and Control (ICISC 2018), , pp 351-357 , Jan 2018. .
- [2]. Prof. Kiran. Mensinkai, Chaitra B.V, Chinmayi V Pandith, Goutam P Nayak and Jyothsna C. S, "AN INTELLIGENT SAFETY SYSTEM FOR INDIVIDUAL'S SECURITY", IEEE International Conference on Energy, Communication, Data Analytics and Soft Computing (ICECDS 2017), pp 1117- 1122, Aug 2017 .
- [3]. G C Harikiran, Karthik Menasinkai, Suhas Shirol, "SMART SECURITY SOLUTION FOR WOMEN BASED ON INTERNET OF THINGS (IOT)", IEEE International Conference on Electrical, Electronics, and Optimization Techniques (ICEEOT 2016), pp 3551-3554 , Mar 2016.
- [4]. Dr C K Gomathy, Ms D. Geetha, "WOMEN SAFETY DEVICE USING IOT" International Journal of Scientific Research in Engineering & Management: Vol 05, Issue 10, pp 1-9 , ISSN 2582-3930 Oct 2021.
- [5]. Dhruvil parikh, Prof Sudhir kadam, et.al, "IOT based Wearable Safety Device for Women" International Journal of Engineering Research & Technology" Vol 9, Issue 05, pp 1086-1089, ISSN 2278-0181 May 2020.
- [6]. C Pratheeba, K.R, Archana, et.al, "A SMART WEARABLE DEVICE WOMEN SAFETY SYSTEM BASED ON IOT", International Research Journal of Modernization in Engineering Technology and Science" Vol 03, Issue 03 , pp 20-27, e-ISSN 2582-5208, March 2021.
- [7]. Sanila K , Dr. Sindhu R, "Wearable Device for Women Safety and Defence" International Journal of Advanced Research in Science, Communication and Technology "Vol 2, Issue 2, pp 487-493, ISSN 2581-9429, April 2022,
- [8]. S.K. Anisha, S. Chandana, et.al, "Women's Wearable Security and Safety Device", International Journal of Recent Technology and Engineering", Vol 9, Issue 4, pp 171-177, ISSN 2277-3878, Nov 2020.
- [9]. Shivani Basargi, Pranita Veer, et.al, "Women Safety Device with GPS Tracking and Alerts", International Research Journal of Engineering and Technology", Vol 77, Issue 2, pp 2158-2161, ISSN: 2395-0072, Feb 2020.
- [10]. V. Hyndavi, N. Sai Nikhita, et.al, "Smart Wearable Device for Women Safety using IoT", 5<sup>th</sup> International Conference on Communications and Electronics System (ICCEs)" pp 459-463, Jun 2020.